

# Double Wall Fuel Storage Tank

Model/Make: 550DWFS / Transcube 20TCG

## Product Description

This tank is designed for the transport of diesel fuel - UN 1202 / UN 1993.\* It is UL142 listed for safe storage of fuel and environmental protection.

(\*While these tanks are legal for the transport of fuel, United Rentals does not transport them loaded with fuel. They are delivered empty and must be empty when picked up at the end of the rental.)

### WEIGHTS and MEASURES

- » **Capacity:** ..... 552 gallons (Max fill should be limited to 95% full – 525 gallons)
- » **Height:** ..... 4'-4" (52 inches)
- » **Width:** ..... 3'-9" (45 inches)
- » **Length:** ..... 7'-6" (90 inches)
- » **Weight:** ..... 6424 lbs.  
(Full – diesel fuel)
- » **Weight (empty):** ..... 1815 lbs.
- » **Fill Point** ..... 3"
- » **Fusible Link Port** ..... 2"

### FEATURES

- » **Secondary Containment:** ..... Double wall construction provides maximum protection (110%) for the environment from leakage or fuel spills.
- » **Lifting Eyes:** ..... Tank can be lifted into position when the tank is full of fuel.
- » **Internal Baffles:** ..... Fuel surge (sloshing) is minimized during transportation and handling.
- » **Fork Lift Pockets:** ..... Ease of handling from all sides.
- » **Tie Down points:** ..... Provides for safe and secure transportation.
- » **Access:** ..... A manhole is provided for easy maintenance and inner tank inspection.
- » **Skid Base:** ..... Heavy duty construction for protecting the tank base from damage.
- » **Security:** ..... Hose access feature enables cabinet to be kept locked while supplying fuel.
- » **Stacking:** ..... Easily stackable (3)-high when empty
- » **Efficiency:** ..... Fuel ports to feed three different pumps

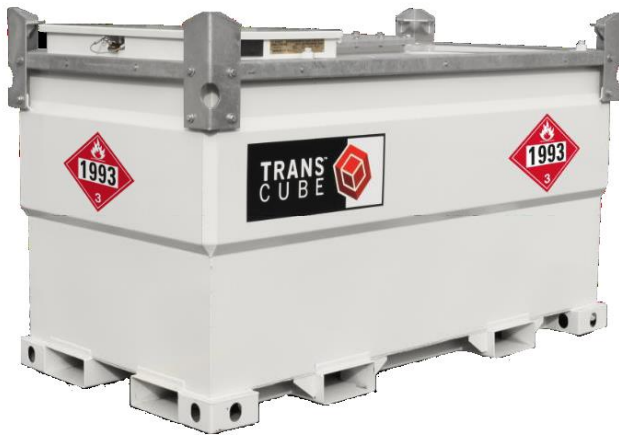

### WETTED MATERIALS (Material Compatibility Check)

- Carbon Steel ..... Inner tank



# Double Wall Fuel Storage Tank

Model/Make: 550DWFS / Transcube 20TCG

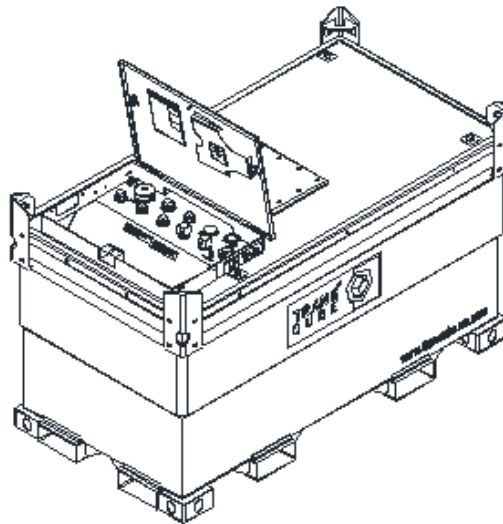
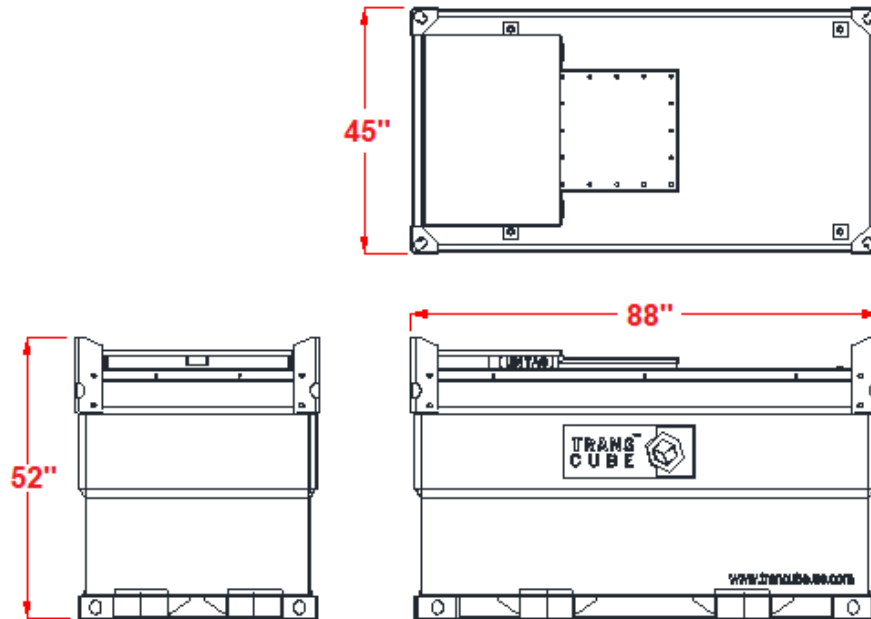

100 First Stamford Place, Ste 700  
Stamford, CT 06902 | USA

UnitedRentals.com | 800.UR.RENTS  
© 2018 United Rentals, Inc

To the best of our knowledge the technical data contained herein are true and accurate at the date of issuance and are subject to change without prior notice. No guarantee of accuracy is given or implied because variations can and do exist. NO WARRANTY OR GUARANTEE OF ANY KIND IS MADE BY UNITED RENTALS, EITHER EXPRESSED OR IMPLIED.