

6" Diesel Pump

Vacuum Assisted

Product Description

Diesel engine driven centrifugal pump equipped with vacuum-assisted priming system. Trailer mounted for easy transportation having the following additional features: Run dry mechanical seal, Auto-start control, monitoring of fuel level, engine load, run time, oil and coolant temperature, and telemetry system.

Technical Data

Operating Parameters

Min. / Max. Flow	377 gpm / 3250 gpm
Min. / Max. Shutoff Head	101 ft (44psi) / 267 ft (116psi)
Maximum Casing Pressure	260 psi
Maximum Temperature	200°F
Maximum Solid Size	3 inch
Min. / Max. Pump Speed	1200 rpm / 1950 rpm

Pump & Accessory Specifications

Suction / Discharge Size	6 inch / 6 inch
Impeller Diameter	14 inch
Vacuum System - Type / Capacity	Diaphragm / 50 CFM

Casing	Ductile Iron ASTM A536 65-45-12
Impeller	CA6NM Stainless Steel
Wear Ring	ASTM A48 Class 40 Gray Iron
Shaft	17-4PH Stainless Steel
Mechanical Seal Faces	Tungsten-Carbide vs Silicon-Carbide
Mechanical Seal Lubrication	ISO Viscosity Grade 32 or Lower <i>(synthetic recommended)</i>
O-rings & Gaskets	Buna-N & Viton
Check Valve Body	Ductile Iron
Check Valve Flapper	Buna-N
Check Valve Type	Swing type

Driver Properties

Type A

Driver Type	Diesel Engine
Driver Make	Duetz
Model	TCD914L6
Max. Continuous Rating	174 hp
Total Displacement	6.5 liters
Aspiration	Turbocharged Charge-Air Cooled
Number of Cylinders	6
Safety Shutdowns	Low Oil Pressure , V Belt , High Temp
Fuel Consumption	6.9 gal/hr @ 1800 rpm
Run Time	19.5 hours @ 1800 rpm
Fuel Type	No. 2 Diesel: NO BIODIESEL
Fuel Capacity	135 U.S. gallons



Notes

- Performance data based on water at 60°F
- Run time indicated is for reference and could vary based on speed and engine loads
- Maximum temperature is the equipment material limitation. Based on the application, process, product and NPSH requirements, the maximum allowable temperature could be lower
- This pump is also available with a 20 CFM venturi-compressor priming system

Type B

Driver Type	Diesel Engine
Driver Make	John Deere
Model	6068HF285
Max. Continuous Rating	173 hp
Total Displacement	6.8 liters
Aspiration	Turbocharged and air-to-airaftercooled
Number of Cylinders	6
Safety Shutdowns	Low Oil Pressure, High Temp.
Fuel Consumption	6.8 gal/hr @ 1800 rpm
Run Time	19.7 hours @ 1800 rpm
Fuel Type	No. 2 Diesel: NO BIODIESEL
Fuel Capacity	135 U.S. gallons

6" Diesel Pump

Vacuum Assisted

Dimensional Drawing

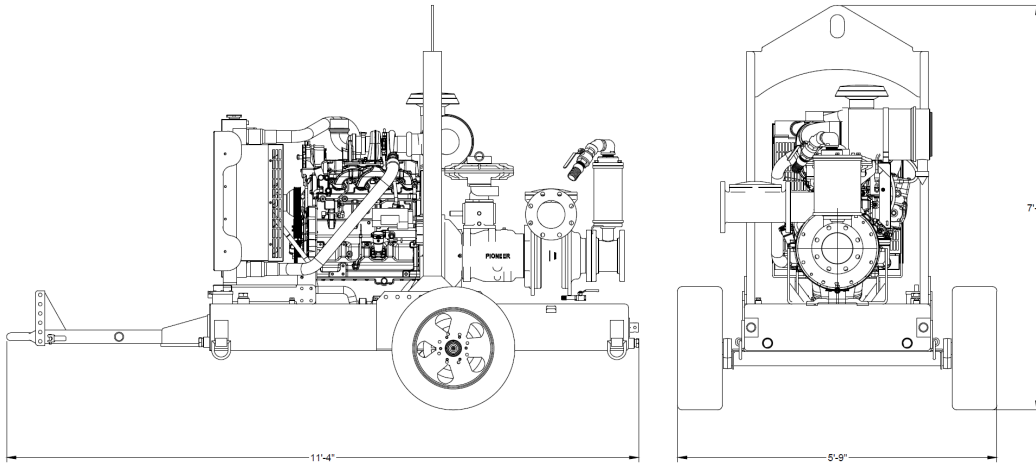

Dimensional Details

Type A	
Total Weight wo/Fuel	3600 lbs
Total Weight w/Fuel	4560 lbs
Overall Height	78 inch
Overall Width	67 inch
Overall Length	145 inch

Type B	
Total Weight wo/Fuel	3720 lbs
Total Weight w/Fuel	4680 lbs
Overall Height	87 inch
Overall Width	69 inch
Overall Length	136 inch

Performance Curve

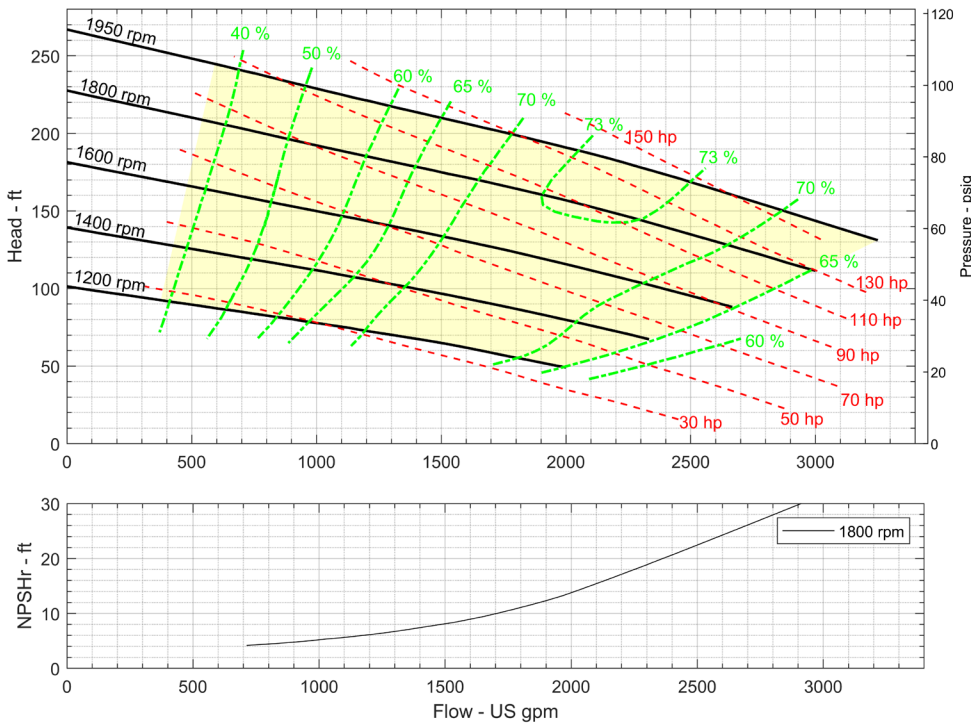

Pump Make	Pioneer Pump
Pump Model	PP66S14
Operating Speed	Variable
Min. Speed	1200 rpm
Max. Speed	1950 rpm
Impeller Rated Dia.	14 inch
Impeller Type	Enclosed
No. of Impeller Vanes	2
Solid Dia.	3 inch
Specific Speed	1832 US Units
Suction Size	6 inch
Discharge Size	6 inch